

EUROMA[®]

LEAD SCREW TAPPING UNITS

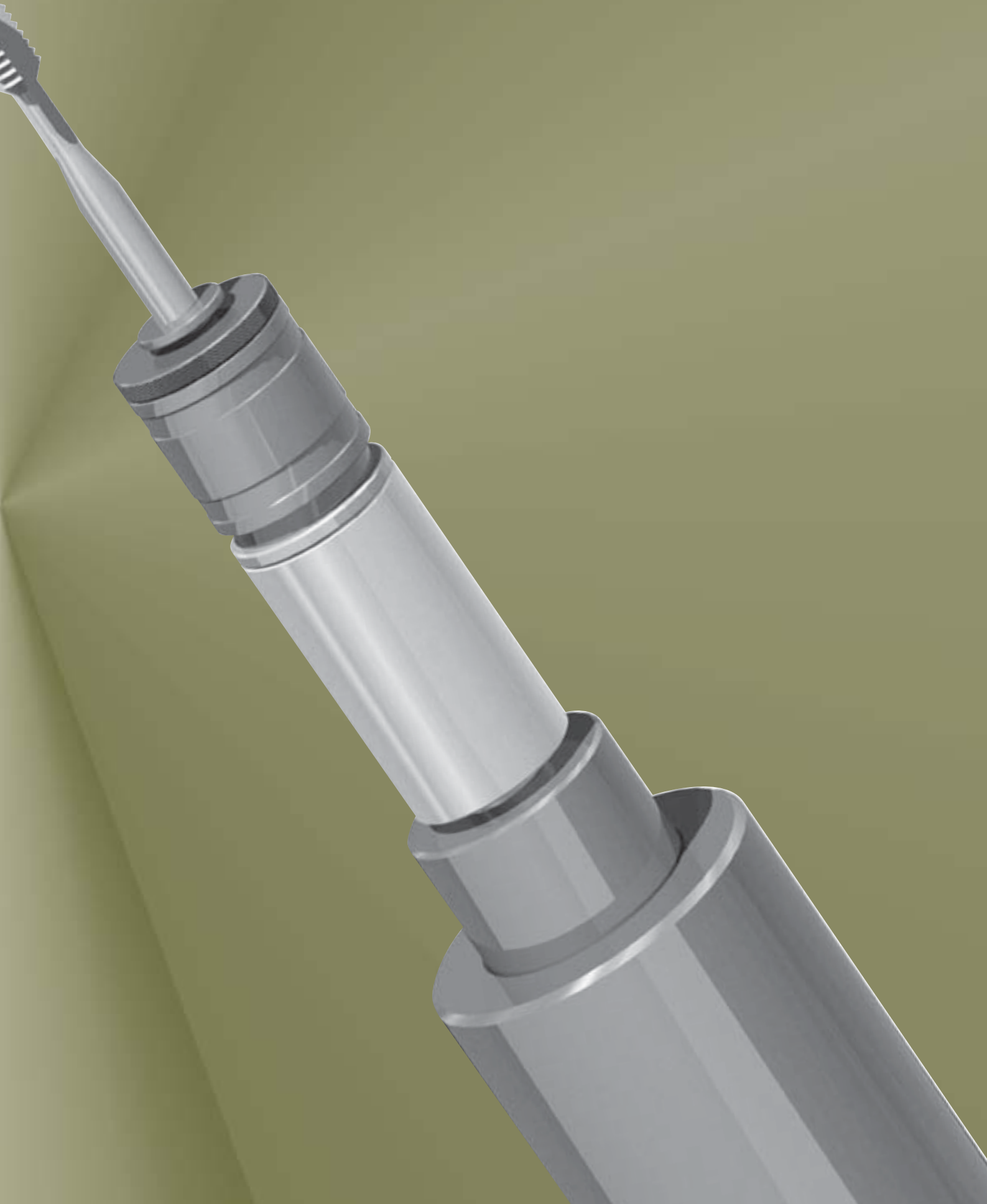

The electro-mechanical tapping unit M.6.50 is available in 50 mm (1.9") stroke.

The standard output spindle is collet type ER11 with collet capacity up to 7mm (.276")

Two micro-switches (NO/NC) are operated at the forward and rear position of the quill.

The self-braking motor ensures the immediate stop of the spindle at the end of the strokes.

The lead screw/nut, operating in a self-contained oil-bath, is fitted on rear of the spindle axis.

A safety device is built into the lead screw housing by which, in case of any excessive axial resistance, a micro-switch is operated and motor rotation can be reversed.

The motor/spindle drive is a toothed belt.

It is essential to order the basic unit complete with the following necessary components.

Spindle speeds lower than 1000 RPM are obtainable by fitting either reduction gear R. 6 between motor and pulley case or a special motor.

Unit is operated by electric power supply only.



Please note the range of our standard accessories on next page.



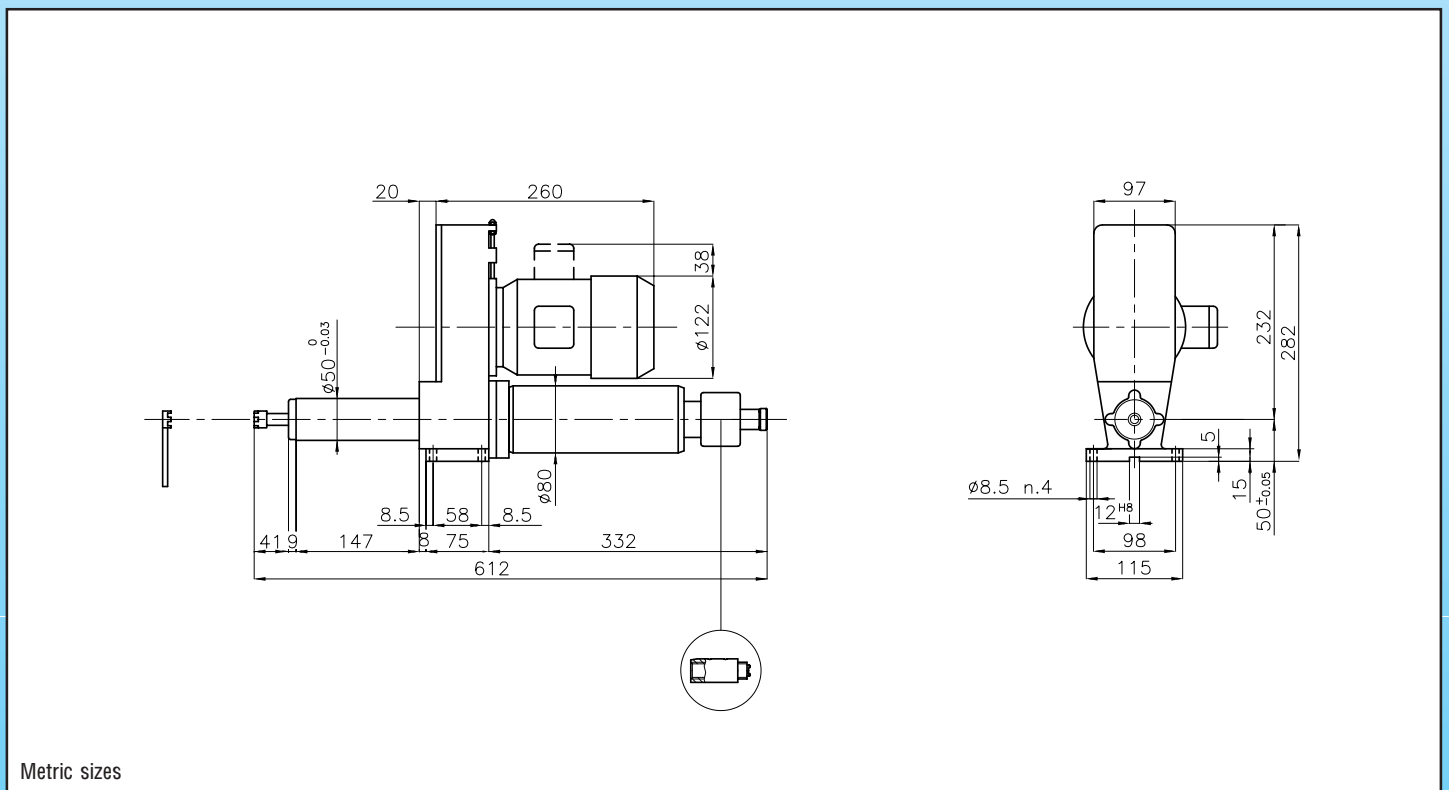

	TECHNICAL DATA									
	TOTAL STROKE mm (inch)	TAPPING CAPACITY mm (inch)		WEIGHT - Kgs (lbs)	STANDARD COLOR - RAL	ELECTRIC PORTS PG (NPT)	PNEUM./HYDR. PORTS PG-NPT	SPINDLE RUNOUT mm (inch) - T.I.R.	LEAD SCREW	
		MILD STEEL	ALLUMINIUM BRASS						HARDENED AND GROUND	IN OIL BATH
M.6.50	50 (1.9")	M6 (1/4")	M8 (5/16")	15 (33)	7035	9 (1/2")		0.02 (.0008")		



BASIC UNIT		SPEED	
MODEL	CODE	50Hz	60Hz
M.6.50	10201200	■ 1000	1200
	10201202	■ 1500	1800
	10201204	● 2000	2400
	10201206	● 3000	3600
 KW 0.37 2P 63 FRAME ● KW 0.24 4P 63 FRAME ■			

NECESSARY COMPONENTS	
LEAD SCREW/NUT	TYPE
	M.P610 Page 62-63
TOOL HOLDERS	TYPE
	collet Page 131 E.ZER11
SERVICE KEY	TYPE
	E.ZE11M code 44550012

ACCESSORIES	
CONTROL PANEL	TYPE
	Please consult engineering office
REDUCTION GEAR	TYPE
	R 6 Please consult engineering office

UNITS ASSEMBLY BY CLAMPING ON FRONT BODY

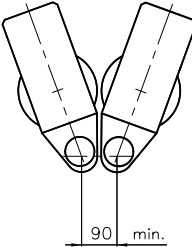
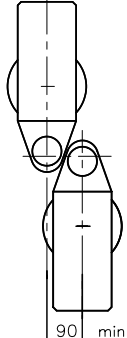
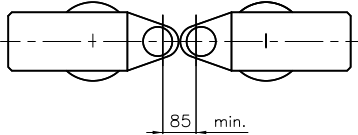



NOTE: FOR THESE APPLICATIONS, PLEASE SPECIFY ON ORDER "WITHOUT FIXING BASE"

Metric sizes

STANDARD MOUNTING COMPONENTS

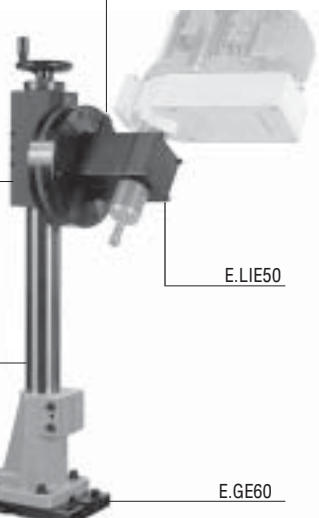
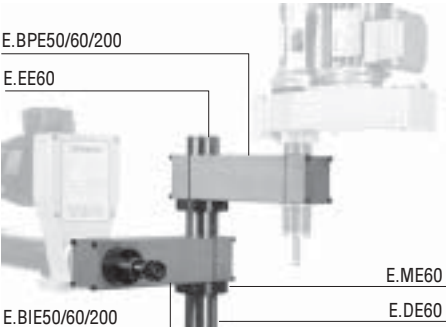
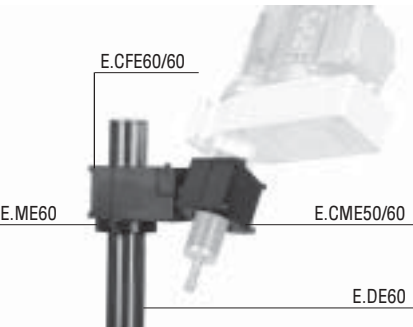
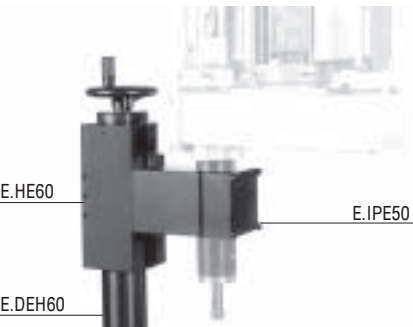
FOR DIMENSIONAL FEATURES OF ALL MOUNTING COMPONENTS, PLEASE SEE FROM PAGES 142

 <p>E.JE85/2000</p> <p>E.HE60</p> <p>E.LIE50</p> <p>E.DEH60</p> <p>E.GE60</p>	 <p>E.BPE50/60/200</p> <p>E.EE60</p> <p>E.ME60</p> <p>E.DE60</p> <p>E.BIE50/60/200</p> <p>E.FE50</p>	 <p>E.CFE60/60</p> <p>E.ME60</p> <p>E.CME50/60</p> <p>E.DE60</p>
		 <p>E.HE60</p> <p>E.IPE50</p> <p>E.DEH60</p>

The electro-mechanical tapping unit M.12 is available in 50 or 100 mm (1.9" or 3.9") stroke. Model M.12.100 features a 50 mm (1.9") fast travel as part of the 100 mm (3.9") stroke. Two micro-switches (NO/NC) are operated at the forward and rear position of the quill.

The brake motor ensures the immediate stop of the spindle at the ends of the stroke.

The lead screw/nut arrangement (operating in oil-bath) is fitted on the spindle axis for side loads free movement and high reliability tapping. Screw is of high quality hardened and ground steel.

A safety device is built into the lead screw housing by which, in case of any excessive axial resistance, a micro-switch is operated and motor rotation can be reversed.

The motor/spindle drive is via toothed pulleys/belt arrangement.

It is essential to order the basic unit complete with the following necessary components.

Tool holding options:

- B12 TAPER = AT1
- ER20 COLLET HOLDER (cap .04"±.512") = AT3
- ST16 STRAIGHT SHANK - DIN 55058 = AT4
- MT1 No 1 MORSE TAPER = AT5
- B12 TAPER (M.10.100 only) = AT15
- ER16 COLLET HOLDER (cap .04"±.394") (M.10.100 only) = AT17



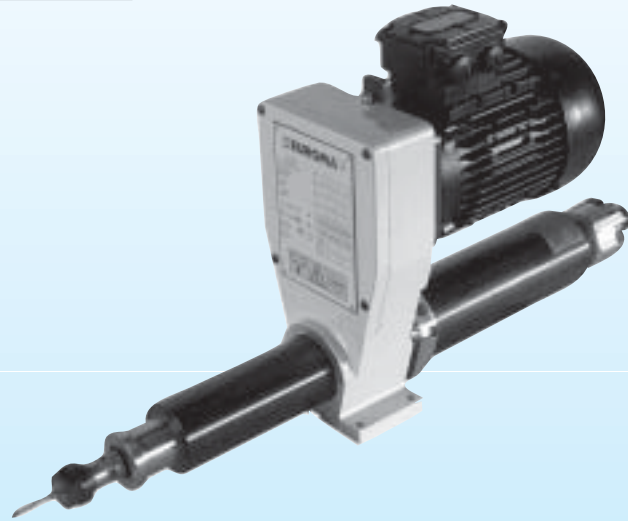

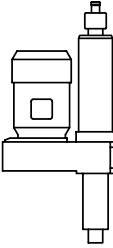

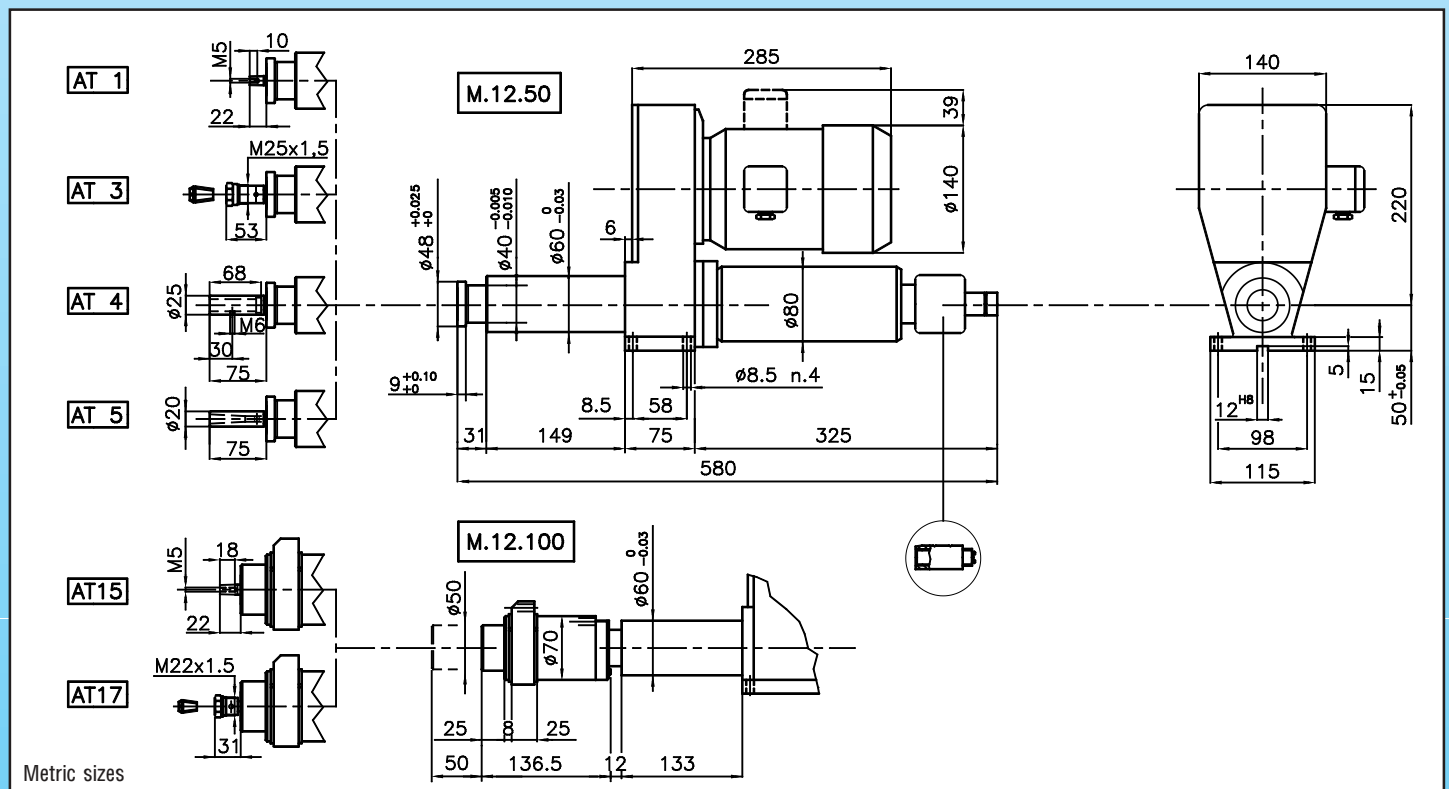
Please note the range of our standard accessories on next page.







	TECHNICAL DATA									
	TOTAL STROKE mm (inch)	TAPPING CAPACITY mm (inch)		WEIGHT - Kgs (lbs)	STANDARD COLOR - RAL	ELECTRIC PORTS PG (NPT)	PNEUMATIC PORTS BSP-NPT	SPINDLE RUNOUT mm (inch) - T.I.R.	LEAD SCREW	
		MILD STEEL	ALLUMINIUM BRASS						HARDENED AND GROUND	IN OIL BATH
M.12.50	50 (1.9")	M12 (1/2")	M16 (5/8")	20 (44)	7035	PG9 (1/4")		0.02 (.0008")	HARDENED AND GROUND	IN OIL BATH
M.12.100	100 (3.9")	M12 (1/2")	M16 (5/8")	24 (53)	7035	PG9 (1/4")	1/8"G	0.02 (.0008")	HARDENED AND GROUND	IN OIL BATH











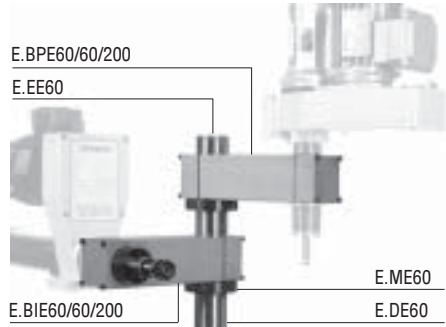
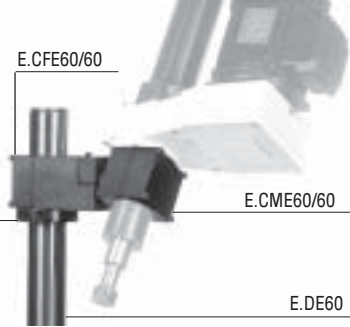

BASIC UNIT		SPEED	
MODEL	CODE	50Hz	60Hz
M.12.50	10201226	▲ 460	552
	10201228	■ 700	840
	10201230	■ 1050	1260
	10201232	■ 1600	1920
	10201234	■ 2400	2880
M.12.100	10201254	▲ 460	552
	10201256	■ 700	840
	10201258	■ 1050	1260
	10201260	■ 1600	1920
	10201262	■ 2400	2880
M.R12.50	10201224	▲ 150	180
	10201222	■ 230	276
M.R12.100	10201250	▲ 150	180
	10201252	■ 230	276
 KW 0.50 4P 71 FRAME ■ KW 0.55 6P 80 FRAME ▲			

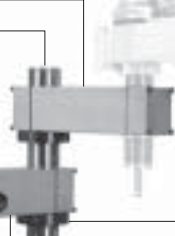
NECESSARY COMPONENTS	
TOOL HOLDERS M.12.50	TYPE
	AT 1 code 28010012
	AT 3 code 28010016 collet Page131 E.ZER20
	AT 4 code 28010020
	AT 5 code 28010024
TOOL HOLDERS M.12.100	TYPE
	AT15 code 28010060
	AT17 code 28010064 collet Page131 E.ZER16
LEAD SCREW / NUT	TYPE
	M.P610 Page 62-63

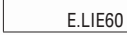
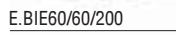
ACCESSORIES		
OPTIONAL MODELS	CODE	SPEED 50 Hz
M.12.50.A M.12.100.A	10201240 10301245	3 speeds units: 450 740 - 1000 RPM (chain drive).
QUICK RELEASE CHUCK		TYPE
		Page 128-129
TAP HOLDERS		TYPE
		Page 130
CONTROL PANEL		TYPE
		Please consult engineering office
MULTI-SPINDLE HEADS		TYPE
		V Page 118

STANDARD MOUNTING COMPONENTS

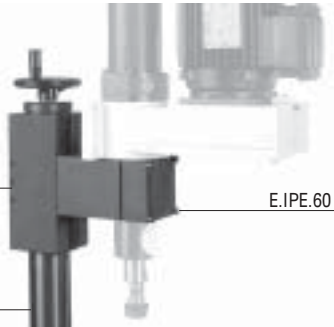
FOR DIMENSIONAL FEATURES OF ALL MOUNTING COMPONENTS, PLEASE SEE FROM PAGES 142

 <p>E.JE85/200</p>	 <p>E.BPE60/60/200</p>	 <p>E.CFE60/60</p>
 <p>E.HE60</p>	 <p>E.EE60</p>	 <p>E.ME60</p>
 <p>E.LIE60</p>	 <p>E.BIE60/60/200</p>	 <p>E.DE60</p>
 <p>E.DEH60</p>	 <p>E.FE60</p>	 <p>E.IPE.60</p>
 <p>E.GE60</p>		 <p>E.DEH60</p>

The electro-mechanical tapping units M.16/M.20 are available in 80 or 130 mm (3.15" or 5.12") stroke.

Models M.16.130 and M.20.130 feature a 50 mm (1.9") fast travel as part of the 130 mm (5.12") stroke. Two micro-switches (NO/NC) are operated at the forward and rear position of the quill.

The brake motor ensures the immediate stop of the spindle at the ends of the stroke.

The lead screw/nut, operating in a self-contained oil-bath, is fitted on the rear spindle axis. The screw is made of high quality hardened and ground steel.

A safety device is built into the lead screw housing by which, in case of any excessive axial resistance, a micro-switch is operated and motor rotation can be reversed.

The motor/spindle drive is via sprockets/chain or toothed belt.

It is essential to order the basic unit complete with the following necessary components.

Tool holding options:

- B18 TAPER = AT6
- No 6 JACOBS TAPER = AT26
- ER25 COLLET HOLDER (cap .04"±.630") = AT7
- MT2 No 2 MORSE TAPER = AT9
- ST28 STRAIGHT SHANK = AT25
- B12 TAPER (M.16/M.20.130 only) = AT15
- ER16 COLLET HOLDER (cap .04"±.394") (M.16/M.20.130 only) = AT17



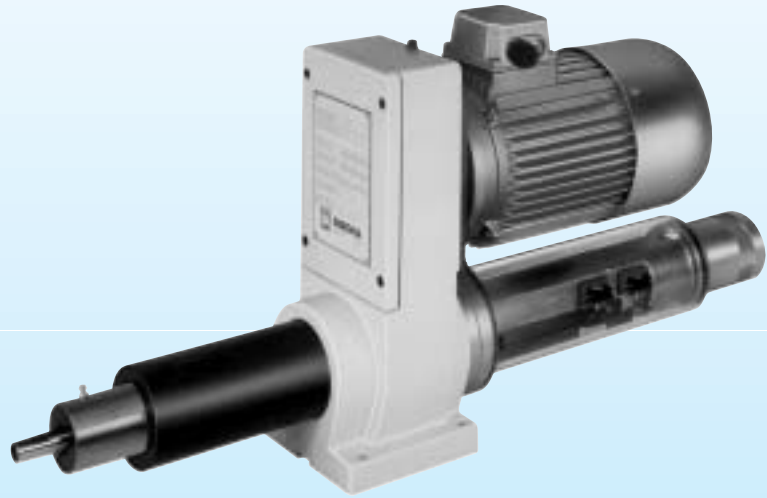



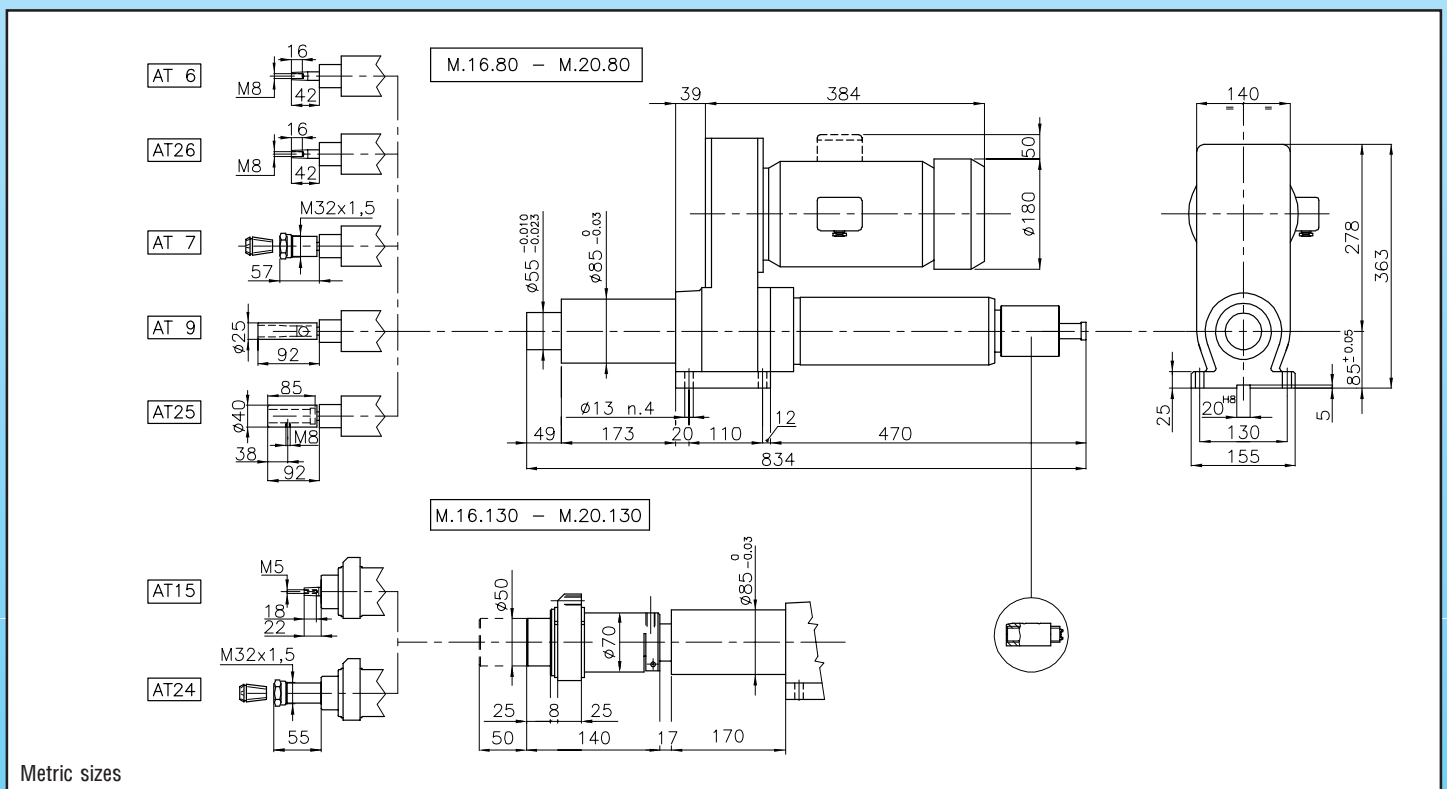

Unit is operated by electric power supply only. Please note the range of our standard accessories on next page.







	TECHNICAL DATA							LEAD SCREW		
	TOTAL STROKE mm (inch)	MILD STEEL	ALLUMINIUM BRASS	WEIGHT - Kgs (lbs)	STANDARD COLOR - RAL	ELECTRIC PORTS PG (NPT)	PNEUMATIC PORTS BSP-NPT	SPINDLE RUNOUT mm (inch) - T.I.R.	HARDENED AND GROUND	IN OIL BATH
M.16.80	80 (3.15")	M16 (5/8")	M22 (7/8")	38 (84)	7035	9 (1/2")		0.02 (.0008")		
M.16.130	130 (5.12")	M16 (5/8")	M22 (7/8")	41 (90)	7035	9 (1/2")	1/8"G	0.02 (.0008")		
M.20.80	80 (3.15")	M20 (13/16")	M27 (1.1/8")	40 (88)	7035	9 (1/2")		0.02 (.0008")		
M.20.130	130 (5.12")	M20 (13/16")	M27 (1.1/8")	43 (95)	7035	9 (1/2")	1/8"G	0.02 (.0008")		



BASIC UNIT		SPEED	
MODEL	CODE	50Hz	60Hz
M.16.80	10201300	▲ 320	384
	10201302	■ 500	600
	10201304	● 1000	1200
	10201308	■ 1400	1680
M.16.130	10201320	▲ 320	384
	10201322	■ 500	600
	10201324	● 1000	1200
	10201328	■ 1400	1680
M.20.80	10201350	◆ 300	360
		◆ 500	600
		◆ 750	900
		◆ 1000	1200
M.20.130	10201360	◆ 300	360
		◆ 500	600
		◆ 750	900
		◆ 1000	1200
M.R20.80	10201352	◆ 85	100
		◆ 145	175
		◆ 215	260
		◆ 290	350
M.R20.130	10201362	◆ 85	100
		◆ 145	175
		◆ 215	260
		◆ 290	350
	KW 1.10 2P 80 FRAME KW 0.75 4P 80 FRAME KW 0.55 6P 80 FRAME KW 1.10 6P 90 FRAME	●	
		■	
		▲	
		◆	

NECESSARY COMPONENTS	
TOOL HOLDERS M.14.80-M.18.80	TYPE
	AT 6
	code 28010026
	AT 26
	code 28010070
	AT 7
	code 28010028
	collet Page 131
	E.ZER25 spanner E.ZE25 code 44550114
	AT 9
	code 28010032
	AT 25
	code 28010036
TOOL HOLDERS M.16.130-M.20.130	TYPE
	AT 15
	code 28010060
	AT 24
	code 28010074 collet Page 131 E.ZER16
LEAD SCREW/NUT	TYPE
	M.P1418
	Page 62-63

ACCESSORIES		
OPTIONAL MODELS	CODE	SPEED 50 Hz
M.16.80.A M.16.130.A	10201330 10201340	3 speeds units: 300 500 - 750 1000 RPM (chain drive).
QUICK RELEASE CHUCK		
		Page 128-129
CLUTCH TAP HOLDERS		
TYPE		
		Page 130
CONTROL PANEL		
TYPE		
		Please consult engineering office
MULTI-SPINDLE HEADS		
TYPE		
		V Page 118

STANDARD MOUNTING COMPONENTS

FOR DIMENSIONAL FEATURES OF ALL MOUNTING COMPONENTS, PLEASE SEE FROM PAGES 142

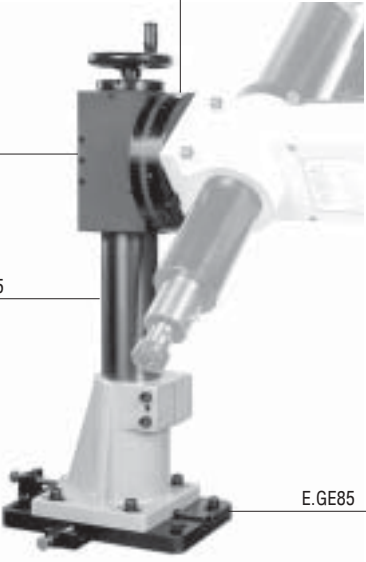
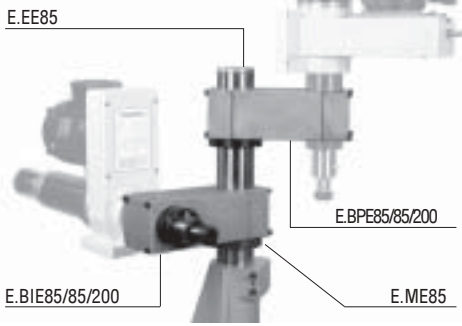
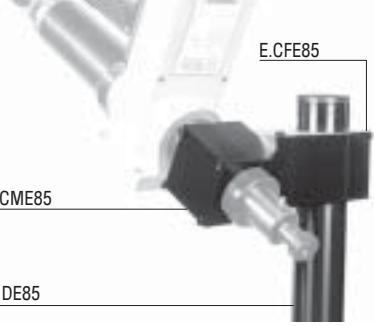
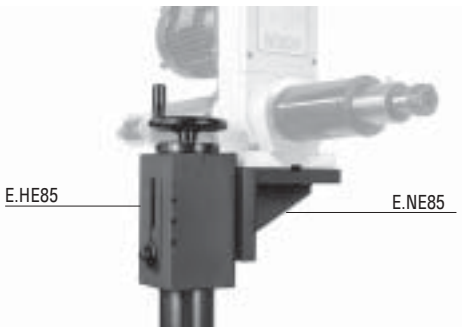
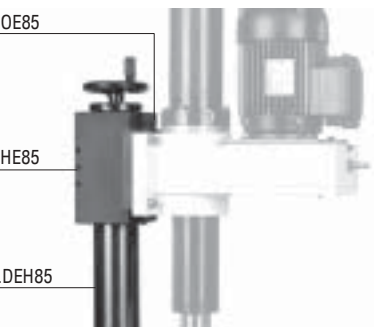
 <p>E.JE85/200</p> <p>E.HE85</p> <p>E.DEH85</p> <p>E.GE85</p>	 <p>E.EE85</p> <p>E.BPE85/85/200</p> <p>E.ME85</p>	 <p>E.CFE85</p> <p>E.CME85</p> <p>E.DE85</p>
	 <p>E.HE85</p> <p>E.NE85</p>	 <p>E.OE85</p> <p>E.HE85</p> <p>E.DEH85</p>

The electro-mechanical tapping units M.28 and M38 are available in either 80 or 120 mm (3.15" or 4.72") strokes.

Model M.28.120 and M.38.120 feature a pneumatically operated fast travel with followings adjustables strokes:

- fast travel 5÷80 mm.
- tapping 0÷40 mm.

Two micro-switches (NO/NC) are operated at the forward and rear position of the quill, and wired to a connector block on the unit.

The brake motor ensures the immediate stop of the spindle at the ends of the stroke.

The lead screw/nut, operating in an self-contained oil-bath, is fitted on the rear spindle axis. The screw is made of high quality hardened and ground steel.

The units are fitted with an internal reduction (1:3 ratio).

A safety device is built into the lead screw housing by which, in case of any excessive axial resistance, (no hole) a micro-switch is operated and motor rotation can be reversed.

The motor/spindle drive is via chain drive.



It is essential to order the basic unit complete with the following necessary components.

Please note the range of our standard accessories on next page.



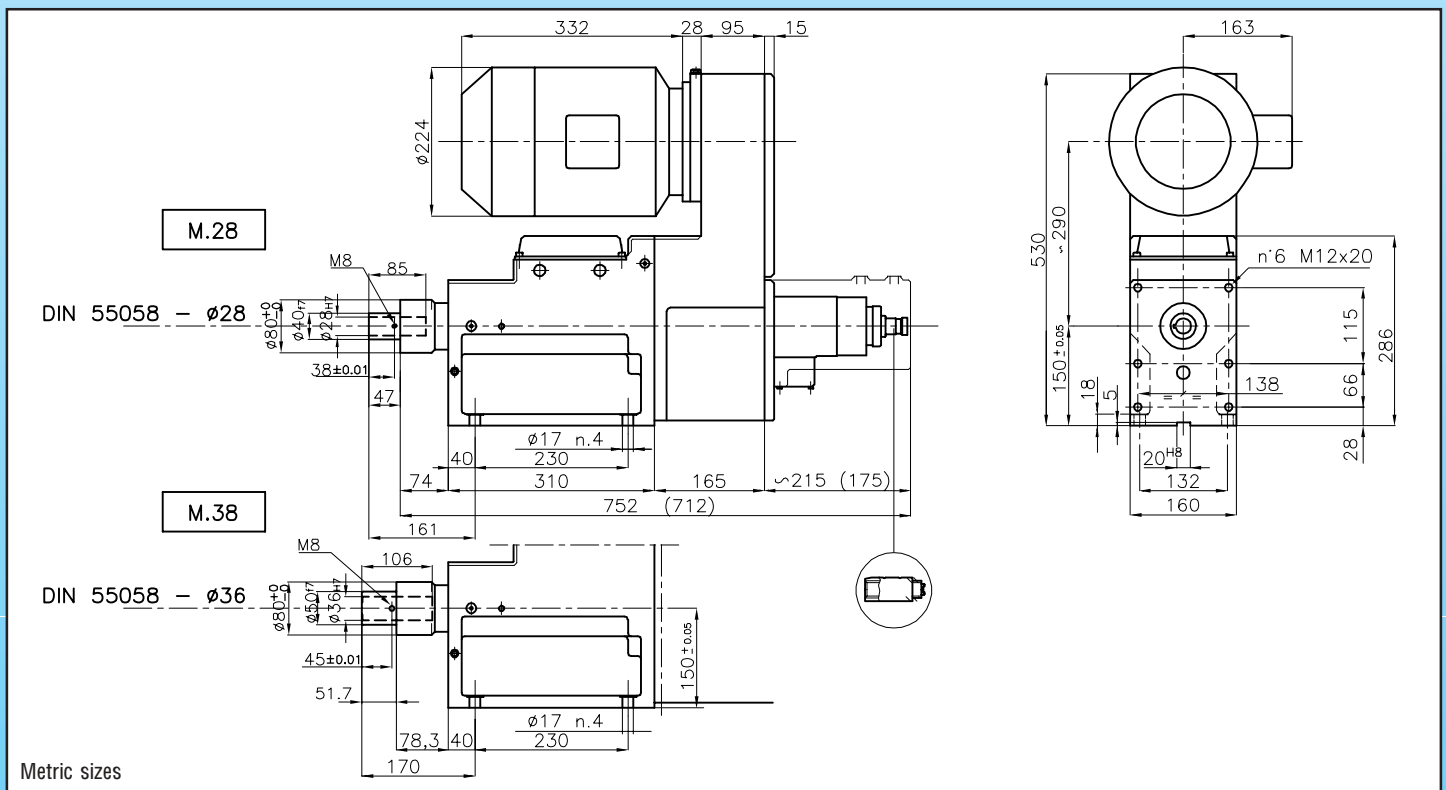

	TECHNICAL DATA								LEAD SCREW	
	TOTAL STROKE mm (inch)	MILD STEEL	ALUMINIUM BRASS	WEIGHT - Kgs (lbs)	STANDARD COLOR - RAL	ELECTRIC PORTS PG (NPT)	PNEUMATIC PORTS BSP-NPT	SPINDLE RUNOUT mm (inch) - T.I.R.	HARDENED AND GROUND	IN OIL BATH
M.28.80	80 (3.15")	M27 (1.1/8")	M39 (1.1/4")	88 (194)	7035	9 (1/2")		0.02 (.0008")	HARDENED AND GROUND	IN OIL BATH
M.28.120	120 (4.72")	M27 (1.1/8")	M39 (1.1/4")	98 (216)	7035	9 (1/2")	1/4"G	0.02 (.0008")		
M.38.80	80 (3.15")	M39 (1.1/4")	M45 (1.1/2")	95 (209)	7035	9 (1/2")		0.02 (.0008")		
M.38.120	120 (4.72")	M39 (1.1/4")	M45 (1.1/2")	105 (232)	7035	9 (1/2")	1/4"G	0.02 (.0008")		



BASIC UNIT		SPEED	
MODEL	CODE	50Hz	60Hz
M.28.80.AT13.A	10202050	100	120
M.28.120.AT13.A	10202054	170	205
		240	290
		390	470
M.28.80.AT13.B	10202051	160	192
M.28.120.AT13.B	10202055	270	325
		370	445
		600	720
MOTORIZATION M.28			
	KW 2,2 6P	112 FRAME	▲
	KW 3 4P	100 FRAME	■
MOTORIZATION M.38			
	KW 3 6P	112 FRAME	●
	KW 4 4P	112 FRAME	◆

BASIC UNIT		SPEED	
MODEL	CODE	50Hz	60Hz
M.38.80.100	10201500	● 100	120
M.38.80.150	10201502	● 150	180
M.38.80.200	10201504	● 200	240
M.38.80.300	10201506	● 300	360
M.38.80.460	10201508	◆ 460	550
M.38.80.590	10201510	◆ 590	700
M.38.120.100	10201512	● 100	120
M.38.120.150	10201514	● 150	180
M.38.120.200	10201516	● 200	240
M.38.120.300	10201518	● 300	360
M.38.120.460	10201520	◆ 460	550
M.38.120.590	10201522	◆ 590	700

NECESSARY COMPONENTS	
LEAD SCREW/NUT	TYPE
	M.P1418 Pag. 62-63

ACCESSORIES	
MULTI-SPINDLE HEADS	TYPE
	V Pag. 118
CONTROL PANEL/CONTROL PANEL	TYPE
	Please consult engineering office

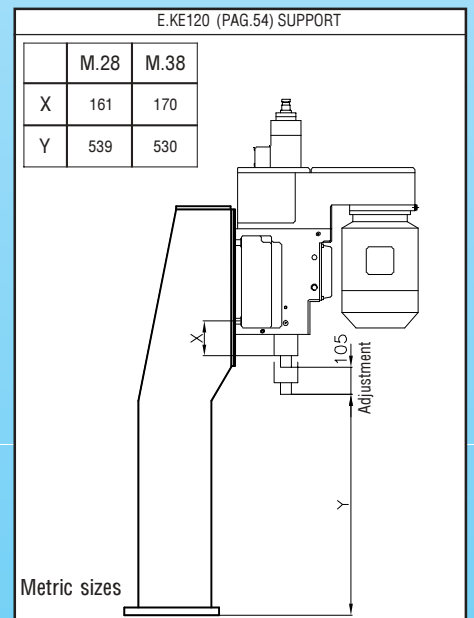
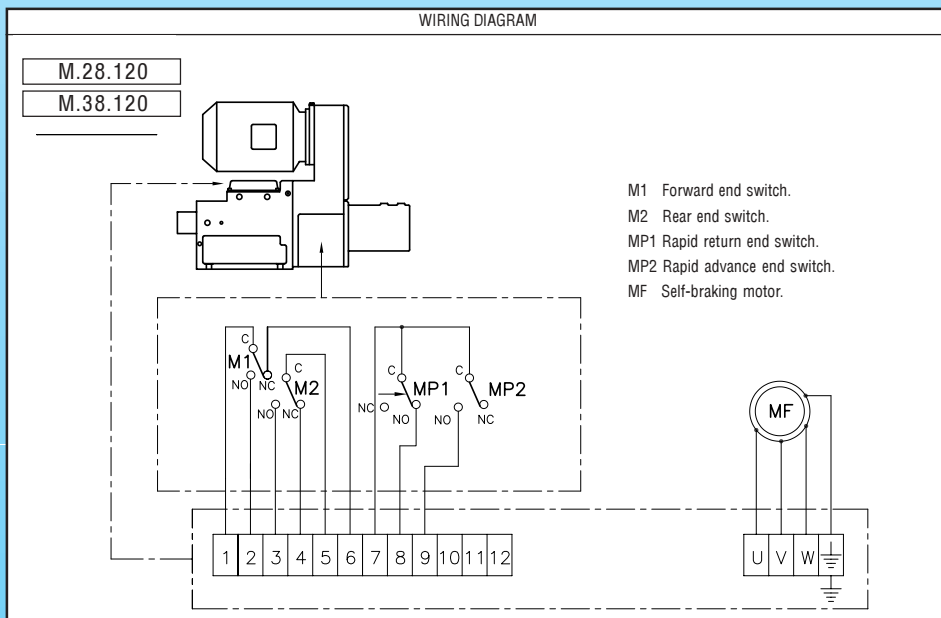
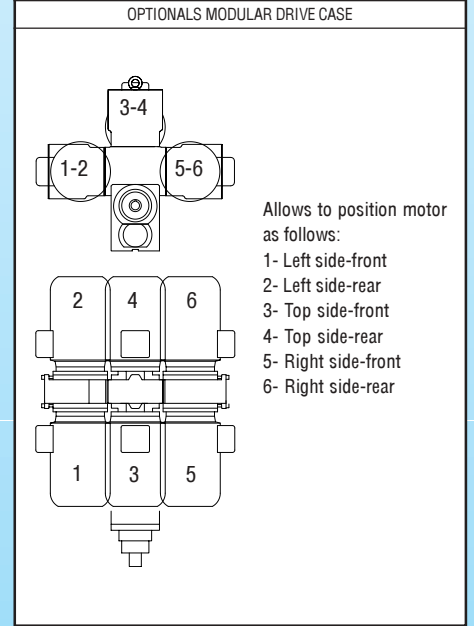
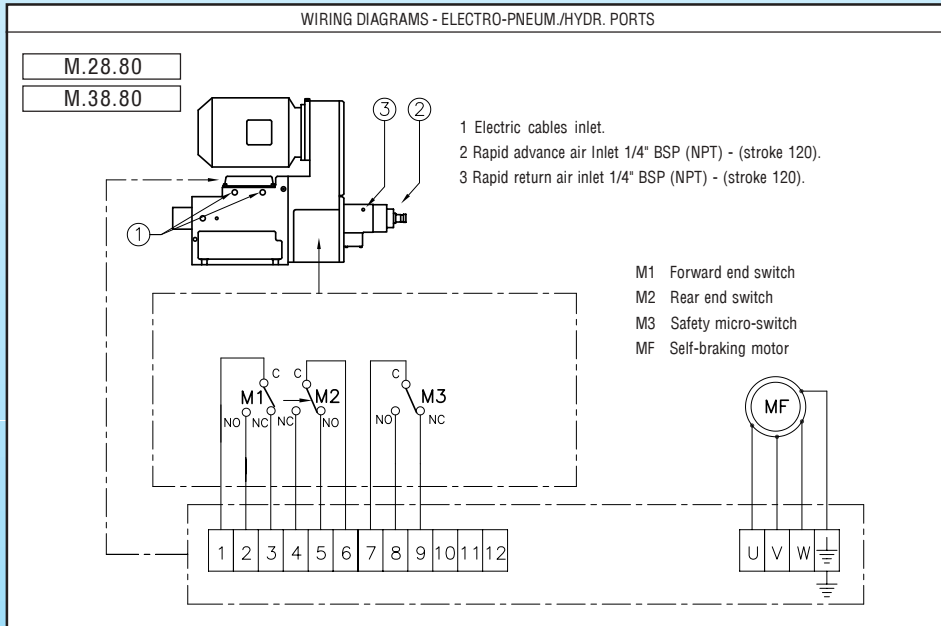

The lead screw type, electro-pneumatic M.42 tapper is supplied in two different working strokes: 80 and 130 mm.

Model M.42.130 is provided with a pneumatic rapid feet and the following adjustable strokes:

- rapid 5+80 mm.
- tapping 0+50 mm.

The unit comes complete with PNP NO+NC adjustable proximity end switches to control the cycle.

The switches are fitted to the left hand side of the unit, but can be transferred to the right hand/one.

The standard brake motor allows the immediate stop of the spindle as soon as the end switches are operated.

It is normally at the rear of the unit, but can be mounted at the front.

The unit can be installed in any position: horizontal, vertical or at any angle.

The lead screw generates the extract spindle feed rate, according to thread pitch to be cut.

It is fitted at rear of the unit and it works in oil bath.

The unit drive features an internal 3 to 1 reduction gear stage.

An adjustable safety device allows the emergency motor reversal in case of tapping in a no hole situation.

Spindle rotation is obtained through a chain drive.

The unit must be ordered together with the "necessary components" (see next page).

Spindle tool holding:

36 mm DIA. STRAIGHT SHANK DIN 55058.



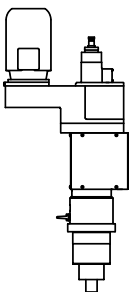

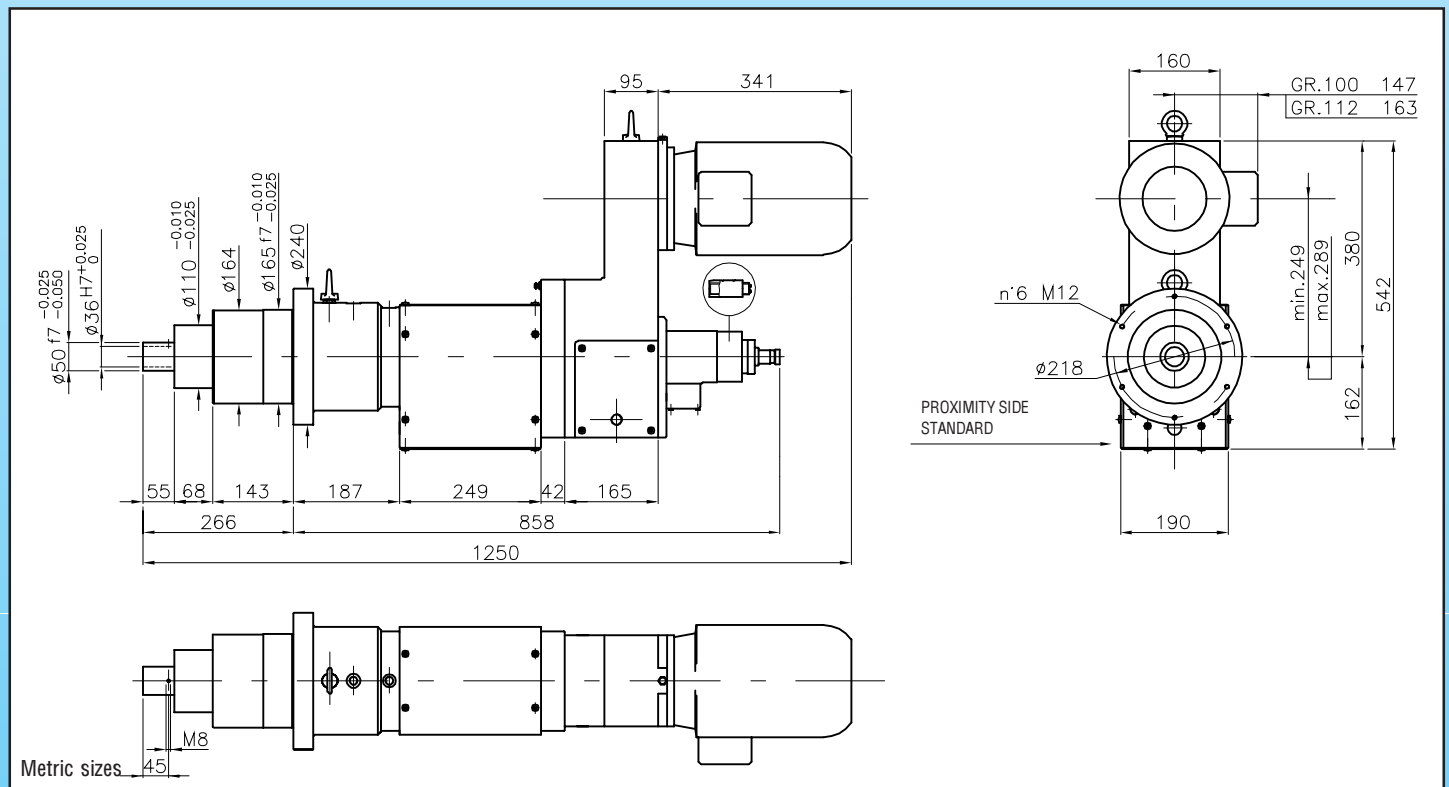
	TECHNICAL DATA									
	TOTAL STROKE mm (inch.)	TAPPING CAPACITY mm (inch)		WEIGHT Kgs (lbs)	STANDARD COLOR RAL	ELECTRIC PORTS PG (NPT)	PNEUMATIC PORTS BSP (NPT)	SPINDLE RUNOUT mm (inch) - T.I.R.	LEAD SCREW	
		MILD STEEL	ALLUMINIUM BRASS						HARDENED AND GROUND	IN OIL BATH
M.42.80	80 (3.14")	M42 (1.1/2")	M45 (1.1/2")	140 (308)	7035	PG13.5		0.02 (.0008")	HARDENED AND GROUND	IN OIL BATH
M.42.130	130 (80+50) (5.1")	M42 (1.1/2")	M45 (1.1/2")	140 (308)	7035	PG13.5	1/4"G	0.02 (.0008")	HARDENED AND GROUND	IN OIL BATH





BASIC UNIT		SPEED		
MODEL	CODE		50Hz	60Hz
M.42.80.100	10201400	▲	100	120
M.42.80.150	10201401	▲	150	180
M.42.80.200	10201402	▲	200	240
M.42.80.300	10201403	▲	300	360
M.42.80.460	10201404	■	460	550
M.42.80.590	10201405	■	590	700
M.42.130.100	10201410	▲	100	120
M.42.130.150	10201411	▲	150	180
M.42.130.200	10201412	▲	200	240
M.42.130.300	10201413	▲	300	360
M.42.130.460	10201414	■	460	550
M.42.130.590	10201415	■	590	700

NECESSARY COMPONENTS

LEAD SCREW/NUT	TYPE
	M.P1418 Page 62-63

	KW 3 6P 112 FRAME ▲ KW 4 4P 112 FRANE ■
-----------------------------------------------------------------------------------	--------------------------------------------

ACCESSORIES

FRONT MOUNTED MOTOR	TYPE
	D Please consult engineering office
MOTORE CON INVERTER INTEGRATO	TYPE
	Please consult engineering office
MULTI-SPINDLE HEAD	TYPE
	Please consult engineering office

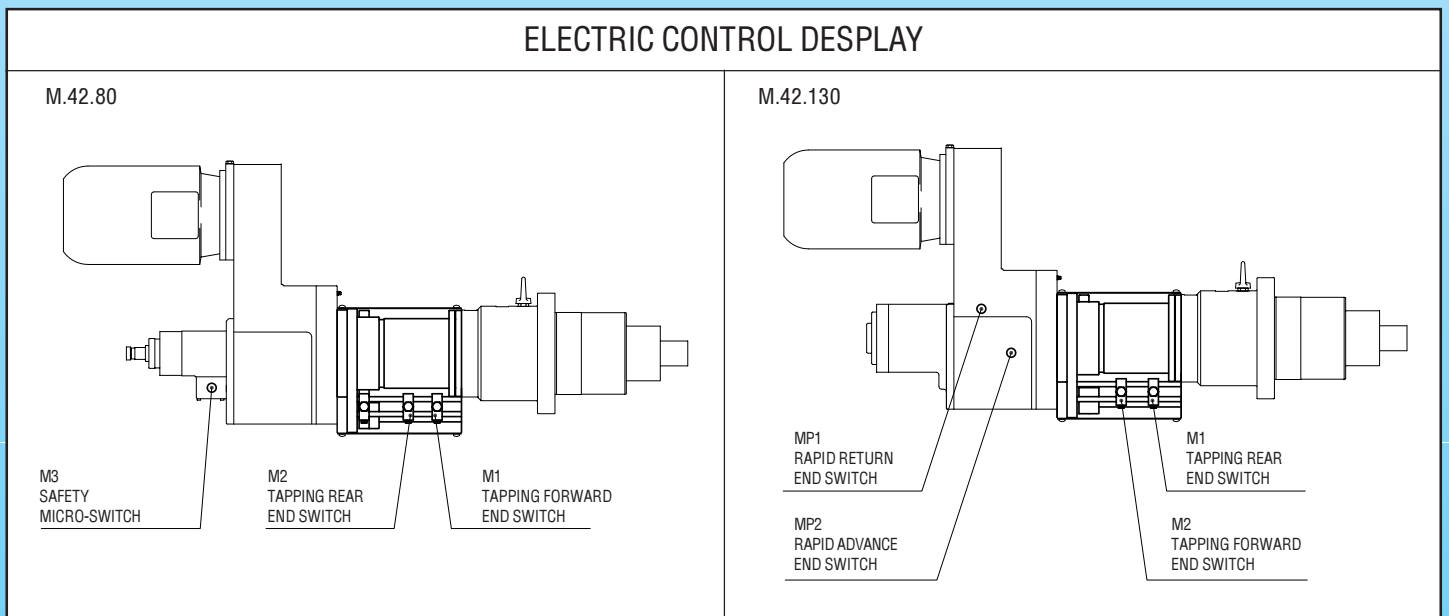
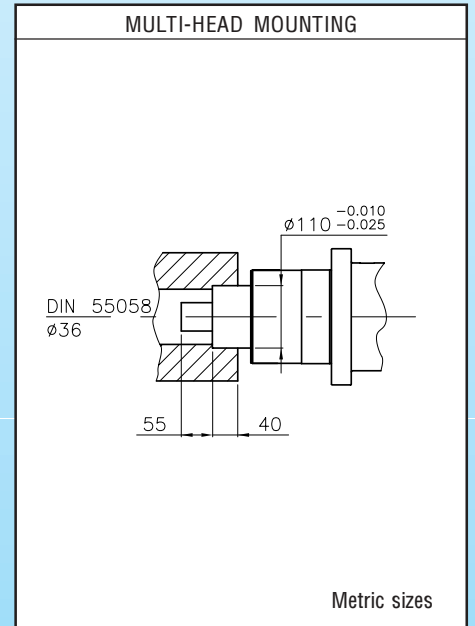
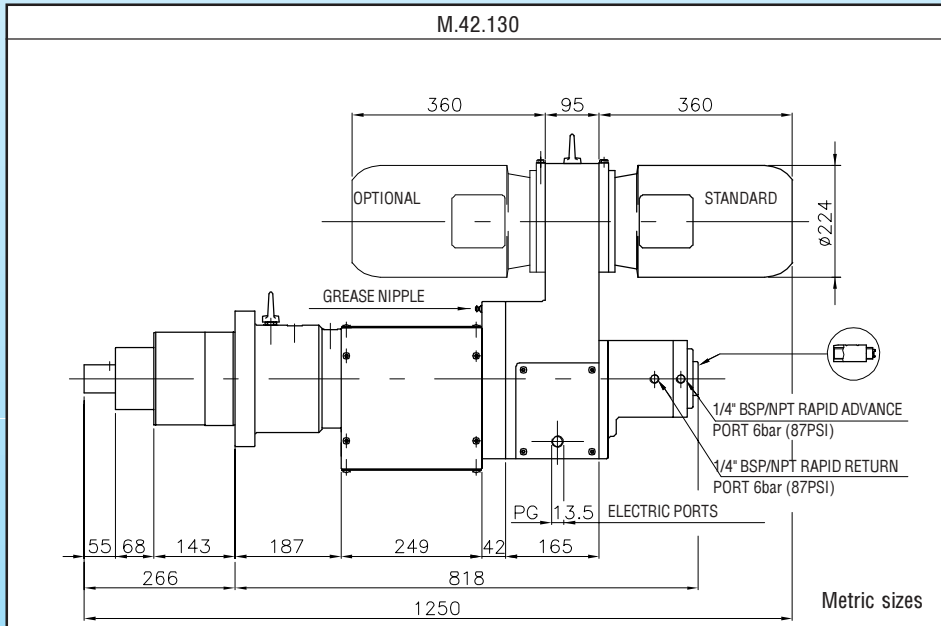

The lead screw/nut is the element which, in relations to the desired pitch, controls the forward thrust of Euroma Tapping spindles.

It is positioned at the rear of the spindle in a self contained oil bath and is made from a bronze B12 casing and an internal 16 Cr Ni 4 screw that has been

case hardened, tempered and ground.

By turning the casing to the other side, the lead screw doubles its life span.

Tapping units M6-M12 use lead screws M.P. 610.

Tapping units M16, M20, M28, M38 use lead screws M.P.1418

Note: Non Standard pitches have the “*” next to them. Left handed treads have the suffix “SX” (example: M.P.610.M.SX)

Special pitches can be made upon request.

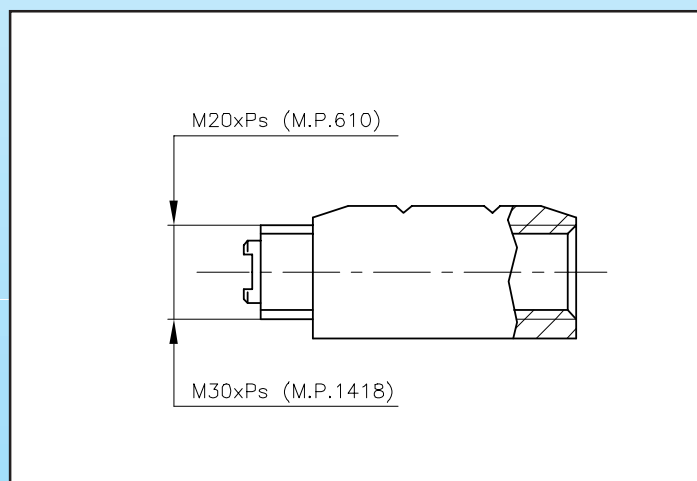
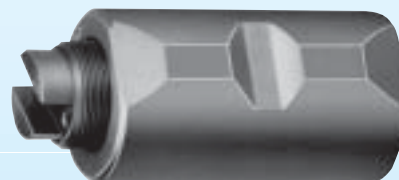

M.P.610			
METRIC THEARDS R.H. (mm)			
UNIT	MODEL	PITCH	CODE
M.6 - M.12	M.P.610.M	0.35	10445024*
	M.P.610.M	0.40	10445026*
	M.P.610.M	0.45	10445028*
	M.P.610.M	0.50	10445030
	M.P.610.M	0.60	10445034
	M.P.610.M	0.70	10445038
	M.P.610.M	0.75	10445040*
	M.P.610.M	0.80	10445042
	M.P.610.M	1	10445044
	M.P.610.M	1.25	10445046
	M.P.610.M	1.50	10445052
	M.P.610.M	1.75	10445054
	M.P.610.M	2	10445056
	NOTE: * Non standard threads		

M.P.610			
METRIC THEARDS L.H. (mm)			
UNIT	MODEL	PITCH	CODE
M.6 - M.12	M.P.610.M	0.35	10445124*
	M.P.610.M	0.40	10445126*
	M.P.610.M	0.45	10445128*
	M.P.610.M	0.50	10445130*
	M.P.610.M	0.60	10445134*
	M.P.610.M	0.70	10445138*
	M.P.610.M	0.75	10445140*
	M.P.610.M	0.80	10445142*
	M.P.610.M	1	10445144*
	M.P.610.M	1.25	10445146*
	M.P.610.M	1.50	10445152*
	M.P.610.M	1.75	10445154*
	M.P.610.M	2	10445156*
	NOTE: * Non standard threads		

M.P.610			
IMPERIAL THREADS R.H. (T.P.I.)			
UNIT	MODEL	PITCH	CODE
M.6 - M.12	M.P.610.I	72	10445062*
	M.P.610.I	64	10445064*
	M.P.610.I	56	10445068*
	M.P.610.I	48	10445070*
	M.P.610.I	44	10445072*
	M.P.610.I	40	10445074*
	M.P.610.I	36	10445076*
	M.P.610.I	32	10445078*
	M.P.610.I	28	10445082*
	M.P.610.I	27	10445084*
	M.P.610.I	24	10445086*
	M.P.610.I	20	10445088*
	M.P.610.I	19	10445090*
	M.P.610.I	18	10445092*

NOTE:* Non standard threads

M.P.610			
IMPERIAL THREADS L.H. (T.P.I.)			
UNIT	MODEL	PITCH	CODE
M.6 - M.12	M.P.610.I	72	10445162*
	M.P.610.I	64	10445164*
	M.P.610.I	56	10445168*
	M.P.610.I	48	10445170*
	M.P.610.I	44	10445172*
	M.P.610.I	40	10445174*
	M.P.610.I	36	10445176*
	M.P.610.I	32	10445178*
	M.P.610.I	28	10445182*
	M.P.610.I	27	10445184*
	M.P.610.I	24	10445186*
	M.P.610.I	20	10445188*
	M.P.610.I	19	10445190*
	M.P.610.I	18	10445192*

NOTE:* Non standard threads

M.P.1418			
METRIC THEARDS R.H. (mm)			
UNIT	MODEL	PITCH	CODE
M.16 - M.20 M.28 - M.38	M.P.1418.M	0.50	10445230
	M.P.1418.M	0.60	10445234
	M.P.1418.M	0.70	10445238
	M.P.1418.M	0.75	10445240*
	M.P.1418.M	0.80	10445242
	M.P.1418.M	1	10445244
	M.P.1418.M	1.25	10445246
	M.P.1418.M	1.50	10445248
	M.P.1418.M	1.75	10445252
	M.P.1418.M	2	10445254
	M.P.1418.M	2.50	10445256
	M.P.1418.M	3	10445258

NOTE:* Non standard threads

M.P.1418			
METRIC THEARDS L.H. (mm)			
UNIT	MODEL	PITCH	CODE
M.16 - M.20 M.28 - M.38	M.P.1418.M	0.50	10445330*
	M.P.1418.M	0.60	10445334*
	M.P.1418.M	0.70	10445338*
	M.P.1418.M	0.75	10445340*
	M.P.1418.M	0.80	10445342*
	M.P.1418.M	1	10445344*
	M.P.1418.M	1.25	10445346*
	M.P.1418.M	1.50	10445348*
	M.P.1418.M	1.75	10445352*
	M.P.1418.M	2	10445354*
	M.P.1418.M	2.50	10445356*
	M.P.1418.M	3	10445358*

NOTE:* Non standard threads

M.P.1418			
IMPERIAL THREADS R.H. (T.P.I.)			
UNIT	MODEL	PITCH	CODE
M.16 - M.20 M.28 - M.38	M.P.1418.I	28	10445282*
	M.P.1418.I	27	10445284*
	M.P.1418.I	24	10445286*
	M.P.1418.I	20	10445288*
	M.P.1418.I	19	10445290*
	M.P.1418.I	18	10445292*
	M.P.1418.I	16	10445294*
	M.P.1418.I	14	10445296*
	M.P.1418.I	13	10445297*
	M.P.1418.I	12	10445298*
	M.P.1418.I	11 1/2	10445300*
	M.P.1418.I	11	10445299*
	M.P.1418.I	10	10445302*
	M.P.1418.I	9	10445304*
	M.P.1418.I	8	10445306*
	M.P.1418.I	7	10445308*

NOTE:* Non standard threads

M.P.1418			
IMPERIAL THREADS L.H. (T.P.I.)			
UNIT	MODEL	PITCH	CODE
M.16 - M.20 M.28 - M.38	M.P.1418.I	28	10445382*
	M.P.1418.I	27	10445384*
	M.P.1418.I	24	10445386*
	M.P.1418.I	20	10445388*
	M.P.1418.I	19	10445390*
	M.P.1418.I	18	10445392*
	M.P.1418.I	16	10445394*
	M.P.1418.I	14	10445396*
	M.P.1418.I	13	10445397*
	M.P.1418.I	12	10445398*
	M.P.1418.I	11 1/2	10445400*
	M.P.1418.I	11	10445399*
	M.P.1418.I	10	10445402*
	M.P.1418.I	9	10445404*
	M.P.1418.I	8	10445406*
	M.P.1418.I	7	10445408*

NOTE:* Non standard threads